

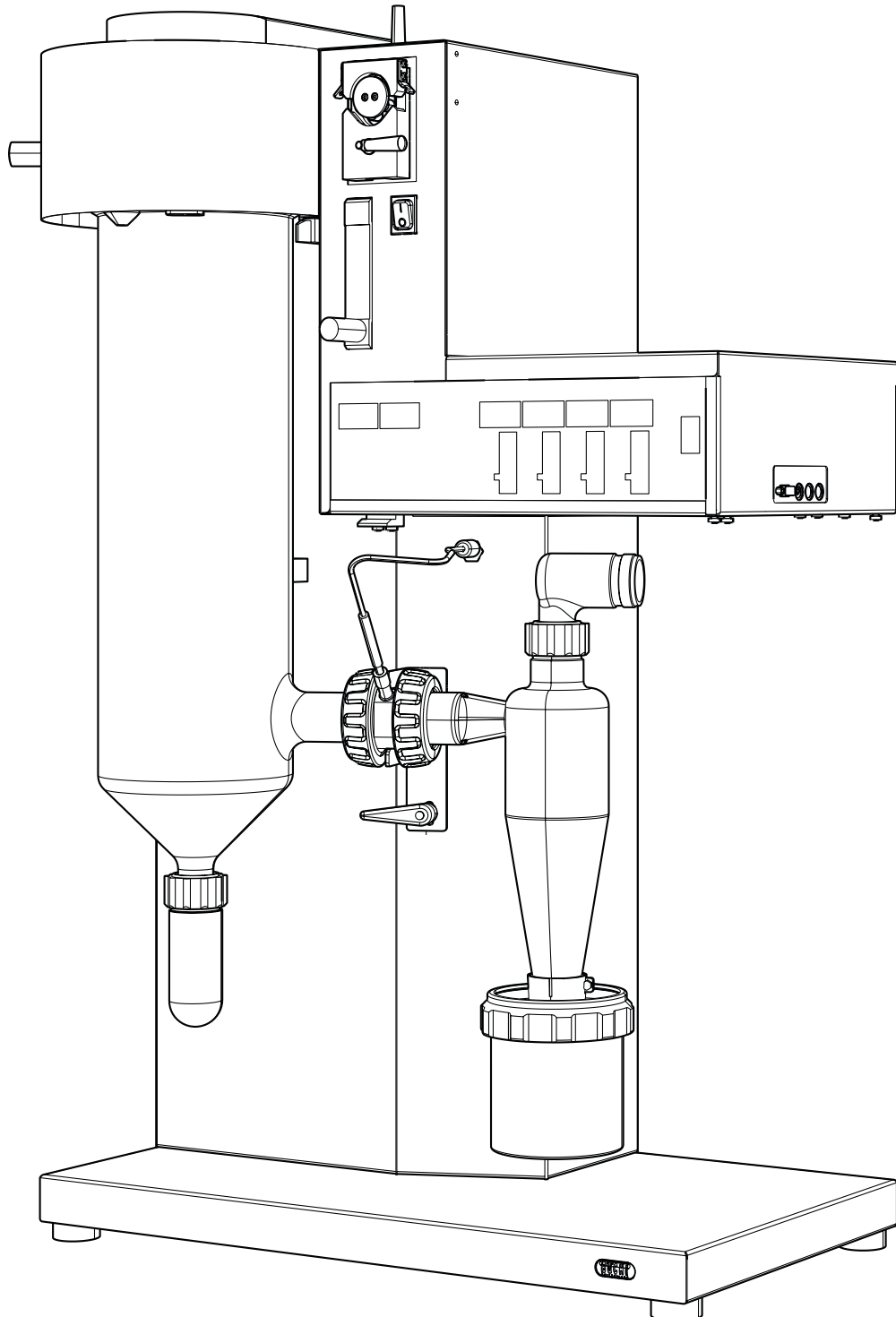

Mini Spray Dryer B-290

Technical data sheet

The Mini Spray Dryer B-290 is the world leading laboratory scale Spray Dryer since many years. It is designed to visualize your Spray Drying process for wide range of applications in various fields such as pharma, materials, chemistry, food, feed, beverages, etc. It allows working with acids, organic solvents or mixtures of aqueous- and organic solvents safely in combination with the Inert Loop B-295 and the Dehumidifier B-296.



Scope of delivery

Components	Qty	B-290 Basic	B-290 Advanced	B-290 acid resistant	B-290 Large
Packing accessories B-290	1	●	●	●	●
Silicone hose D4/7 L=5m	1	●	●	●	●
Two fluid nozzle cpl.	1	●	●		●
Nozzle cleaning brush	1	●	●	●	●
Hose clip 25-40 DIN3017	1	●	●		●
Torx wrench TX 25	1	●	●	●	●
Compressed gas hose	1	●	●	●	●
Hose adapter 4/2	1	●	●	●	●
Hexagonal wrench SW 3.0	1	●	●	●	●
Silicone Hose D2/4	1	●	●	●	●
Silicone labor cable	1	●	●	●	●
Torx wrench TX30	1	●	●	●	●
Power supply	1	●			
Hose Tygon MH2075	1	●	●	●	●
Feed switch valve	1		●		●
Cap nut D1.4	1		●		●
Instruction f. quick couplings	1		●		●
Hose coupling	1	●	●	●	●
Pauch 160x220	1		●		●
Hose Tygon HCF4040A	1		●		●
Two fluid nozzle cpl. special	1			●	
Ultrasonic Package	1				●

Instrument Variants

	“SD organic”	“SD aqueous”	“SD acidic”	“SD Large”
Mini Spray Dryer B-290 basic (200 V)		●		
Mini Spray Dryer B-290 basic (230 V)		●		
Mini Spray Dryer B-290 Advanced (200 V)	●			●
Mini Spray Dryer B-290 Advanced (230 V)	●			●
Mini Spray Dryer B-290 acid resistant (200 V)			●	
Mini Spray Dryer B-290 acid resistant (230 V)			●	
Inert Loop B-295 220 V / 50 Hz	●			
Inert Loop B-295 220 V / 60 Hz	●			
Inert Loop B-295 200 V / 50 Hz	●			
Dehumidifier B-296, 230 V / 50 – 60 Hz	●			
Dehumidifier B-296, 200 V / 50 – 60 Hz	●			
Ultrasonic Package				●

Order code

Choose the configuration according to your needs:

0 4 4 7 8	Mini Spray Dryer B-290 Basic 1 200 V 0 230 V
0 4 4	Mini Spray Dryer B-290 Advanced 700 200 V 699 230 V
1 1 0 5 6 4 2	Mini Spray Dryer B-290 acid resistant 1 200 V 0 230 V
1 1 0	Spray Drying System B-290 Large 60051 200 V 59981 230 V

Technical data

Power consumption	max. 2900 W
Connection voltage	200-230 V ± 10 %
Frequency	50/60 Hz
Evaporating capacity	1.0 l/h H ₂ O, higher for organic solvents
Airflow	max. of 35 m ³ /h

Motor control	Frequency converter
Max. temperature input	220 °C
Heating capacity	2300 W
Heating control	PT-100, fuzzy logic, control accuracy ± 3 °C
Interface	Serial port RS-232 for all parameters
Spray gas	Compressed air or nitrogen / 200 - 800 l/h; 5 - 8 bar
Nozzle tip diameter	0.7 mm standard, other sizes 1.4 and 2.0 mm available
Possible particle diameter range	1 - 25 μm
Mean residence time	1.0 - 1.5 sec.
Pollution degree	2
Installation category	II
Dimensions (W x H x D)	65 x 110 x 70 cm
Weight	46 kg

Environmental conditions (for indoor use only)

Temperature	5 - 35 °C
Altitude	up to 2000 m
Humidity	maximum relative humidity 80 % for temperatures up to -31 °C decreasing linearly to 67 % relative humidity at 35 °C

Material used

Glass assembly	3.3 borosilicate glass
Nozzle / heater / connection piece	Stainless steel 1.4301 / 1.4305
Seal of product collection vessel	FPM (FFKM)
Seal cyclone / cylinder	Silicone
Polypress tube	EPDM
Product feed tube	Silicone and tygon

Accessories

	Qty	Order number
Inert Loop B-295 (50 Hz, 200 V) Allows safe working with organic solvents in combination with the Mini Spray Dryer B-290. Oxygen and pressure sensor included.	1	044779
Inert Loop B-295 (50 Hz, 230 V)	1	044701
Inert Loop B-295 (60 Hz, 200 V)	1	046345
Inert Loop B-295 (60 Hz, 230 V)	1	046344

	Qty	Order number
Dehumidifier B-296 (50/60 Hz, 230 V) Versatile instrument to dry the inlet air for reproducible drying conditions. Also useful to work with organic solvents and water mixtures in combination with the Inert Loop B-295 and the Mini Spray Dryer B-290.	1	040188
Dehumidifier B-296 (50/60 Hz, 200 V)	1	040181
Ultrasonic Package Ultrasonic Nozzle and Controller to upgrade the Mini Spray Dryer B-290 to produce larger particles (10 – 60 µm)	1	110 599 80
Spray chilling accessory (50/60 Hz, 230 V) Accessory to enable spray congealing of hot melts of waxes, polymers and fats with a melting point of maximum 70 °C. Solidification of the liquid melt droplets will take place in a cold air stream.	1	040351
Spray chilling accessory (50/60 Hz, 200 V)	1	040352
Two-fluid nozzle 0.7 mm	1	044698
Three fluid nozzle, complete Nozzle for two independent sample feeds at the same time. Allows to spray dry immiscible samples for microencapsulation applications.	1	046555
Nozzle exchange set 1.4 mm, complete Wider diameter for the two fluid nozzle to work with viscous sample materials.	1	046380
Nozzle exchange set 2.0 mm, complete Wider diameter for the two fluid nozzle to work with viscous sample materials.	1	046381
Glass assembly, complete	1	044680
Standard cyclone complete	1	042884
Large collection vessel for standard cyclone 1.1 L	1	11056990
Spray cylinder	1	044673
High-performance cyclone complete Especially designed for small particles down to 1 µm and to achieve higher yields.	1	046369
Outlet filter, complete Collects the residual particles from the cyclone and protects the user, the environment and the instrument. Available with a polyester deep filter and a PTFE filter membrane. Recommended for all Mini Spray Dryers B-290.	1	044754
Inlet filter, complete Protects the sample from particles of the environmental drying air. Only for open mode.	1	011235
Trolley		041257
Remote control panel With 2 meter long cable to be connected to the Mini Spray Dryer B-290.	1	044702
Pre-cleaning glass set System to pre-clean the Mini Spray Dryer B-290 after working with potentially hazardous substances.	1	044441
Sterile Filter for pre-cleaning glass Stainless steel filter housing with sterile filter element when working with potentially hazardous substances.	1	044435

Functional principle

Step 1 - Heating:

Heat the inlet air to the desired temperature
(max. 220 °C)

Step 2 - Droplet formation:

Two-fluid nozzle for the B-290 and.

Step 3 - Drying chamber:

Conductive heat exchange between drying gas and sample droplets.

Step 4 - Particle collection:

Cyclone technology

Step 5 - Outlet filter:

Collection of finest particles to protect the user and the environment.

Step 6 - Drying gas:

Delivered by aspirator

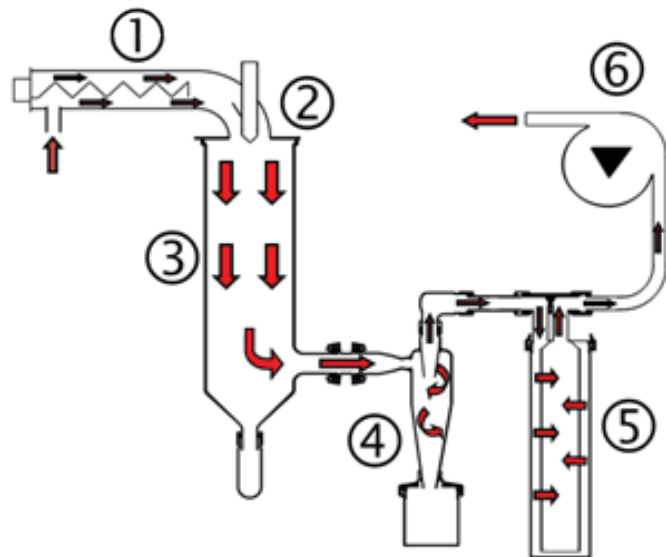

Functional principle of the sample feed dispersion

The Mini Spray Dryer has a integrated two-fluid nozzle: Compressed gas (normally air or N₂) is used to disperse the liquid body into fine droplets which are subsequently dried in the cylinder.

1. Feed solution
2. Peristaltic pump
3. Two fluid nozzle
4. Connection for cooling water
5. Connection for compressed spray gas
6. Automatic nozzle cleaning system

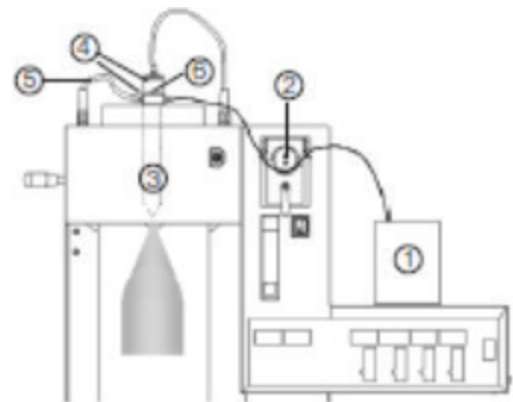

Functional principle of the closed mode with the Inert Loop B-295

1. Feed
2. Product
3. Exhaust gas
4. Solvent
5. Preheat exchanger
6. Condensation
7. Cooling unit

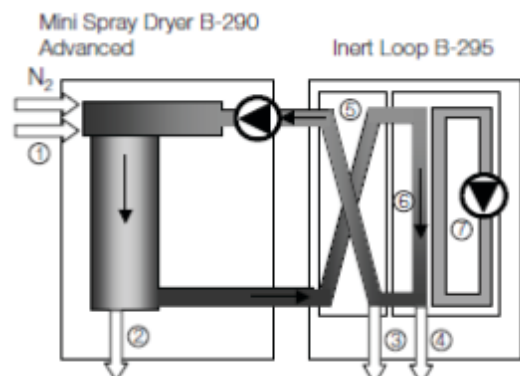

Spray Chilling accessory

Order Code

Choose the configuration according to your needs:



Spray chilling accessory

- 1 50 / 60 Hz, 230 V
- 2 50 / 60 Hz, 200 V

Technical data

Power consumption	max. 400 W
Connection voltage	200-230 V \pm 10 %
Frequency	50/60 Hz
Batch volume	0.3 litre
Heating control (from B-290)	PT-100, fuzzy logic, control accuracy \pm 2°C
Interface	Serial port RS-232 for all parameters
Spray gas	Compressed air or nitrogen / 200 - 800 l/h, 5 - 8 bar
Nozzle tip diameter	0.7 mm standard, other sizes 1.4 and 2.0 mm available
Possible particle diameter range	20 - 200 μ m
Mean residence time	1.0 - 1.5 sec.
Pollution degree	2
Installation category	II
Dimensions (W x H x D)	20 x 20 x 30 cm
Weight	2.4 kg
Heating liquid	Water or a thermal oil (polyethylene glycol PEG 400 with low viscosity)
Heating liquid volume	1.4 litre
Max. melting point of the sample	70°C

Environmental conditions (for indoor use only)

Temperature	5 - 35 °C
Altitude	up to 2000 m
Humidity	maximum relative humidity 80 % for temperatures up to 31 °C decreasing linearly to 67 % relative humidity at 35 °C

Inert Loop B-295

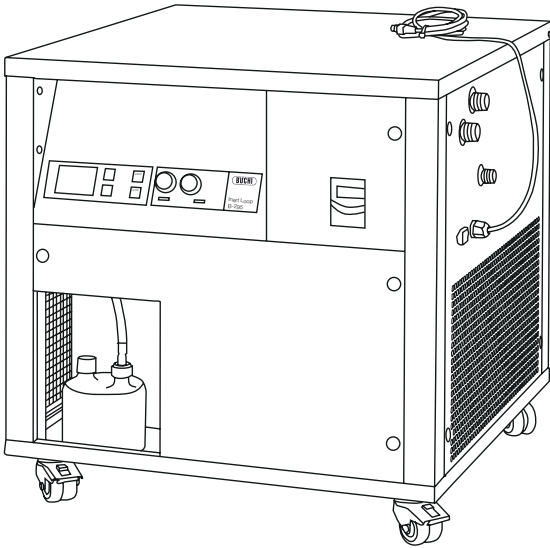

Order Code

Choose the configuration according to your needs:



Inert Loop B-295

4701 220 V / 50 Hz

6344 220 V / 60 Hz

4779 200 V / 60 Hz



Upgrade set Inert Loop B-295

Technical data

Power consumption	max. 1400 W
Connection voltage	200-230 V ± 10 %
Frequency	50/60 Hz
Min. outlet temperature	Down to -20°C
Rate of cooling	800 W at -10 °C
Dimensions (W x H x D)	60 x 70 x 84.5 cm
Weight	88 kg

Environmental conditions (for indoor use only)

Temperature	5 - 35 °C
Altitude	up to 2000 m
Humidity	maximum relative humidity 80 % for temperatures up to 31 °C decreasing linearly to 67 % relative humidity at 35 °C

Dehumidifier B-296

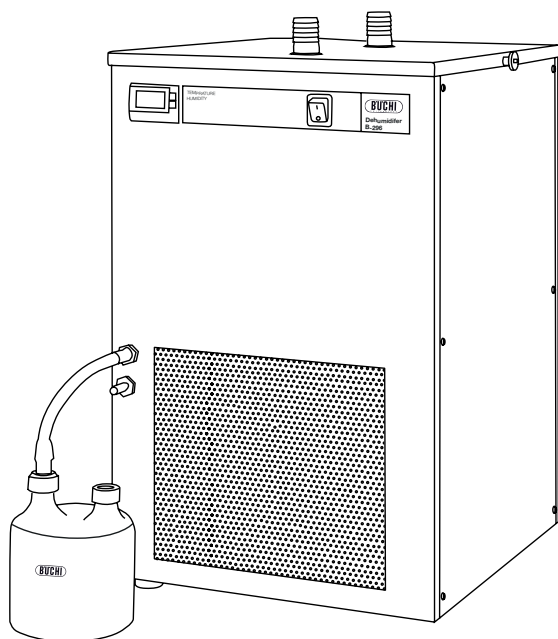

Order Code

Choose the configuration according to your needs:



Dehumidifier B-296

8 230 V / 50 – 60 Hz

1 200 V / 50 – 60 Hz

Technical data

Power consumption	max. 700 W
Connection voltage	200/230 V \pm 10 %
Frequency	50/60 Hz
Min. outlet temperature	0°C
Rate of cooling	600 W at 0 °C
Dimensions (W x H x D)	35 x 60 x 40 cm
Weight	36 kg

Environmental conditions (for indoor use only)

Temperature	5 - 35 °C
Altitude	up to 2000 m
Humidity	maximum relative humidity 80 % for temperatures up to 31 °C decreasing linearly to 67 % relative humidity at 35 °C